



# TOKISTAR LIGHTING INSTRUCTION MANUAL

## KromaStar™ Flex and Globes RGBW Series

### General Description

Tokistar's KromaStar Flex and Globe RGBW Series is a 24VDC lighting system using 0.96 watt Full-Color LEDs. There are three distinct versions available. Each fixture has red, black, and white color-coded wires and is labeled with wattage and operating voltage.

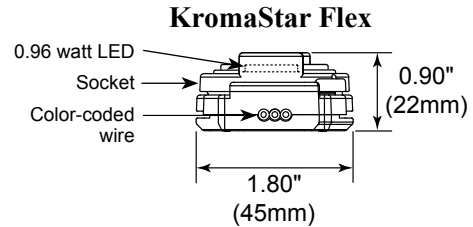

KSF-100 (4" o.c.)-RGBW  
KSF-300 (12" o.c.)-RGBW  
KSF-450 (20" o.c.)-RGBW  
KSF-600 (24" o.c.)-RGBW  
Custom Spacing may have been provided.

### KromaStar Globe Frosted or Clear

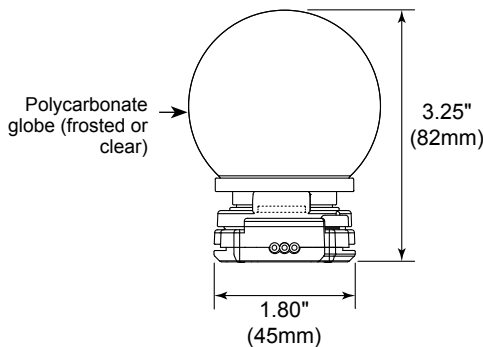

KSG-300 (12" o.c.)-RGBW-G19-F/C  
KSG-450 (20" o.c.)-RGBW-G19-F/C  
KSG-600 (24" o.c.)-RGBW-G19-F/C  
Custom Spacing may have been provided.

### KromaStar Globe w/Virtual Incandescent Lens

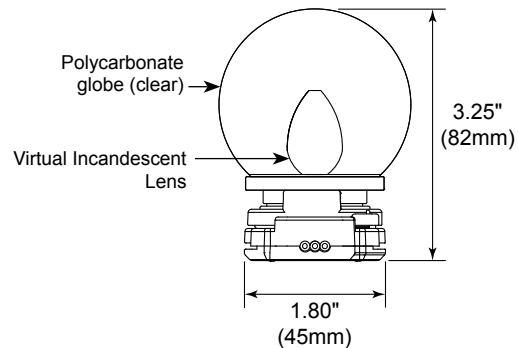

KSG-300 (12" o.c.)-RGBW-VI-G19C  
KSG-450 (18" o.c.)-RGBW-VI-G19C  
KSG-600 (24" o.c.)-RGBW-VI-G19C  
Custom Spacing may have been provided.

### ⚠ PRECAUTIONS

1. Read all instructions completely before beginning installation.
2. Turn off electricity before beginning installation.
3. All wiring is to be performed by a qualified electrician.
4. Installation must comply with the National Electrical Code, and all applicable codes.
5. Turn main supply to the LED driver on only after all connections have been made and tested.
6. Use only LED drivers provided by Tokistar with the system.
7. Do Not place in a location where the fixture may be submerged.

### TOKISTAR® LIGHTING

1015 E. Discovery Lane  
Anaheim, CA 92801  
TEL: 714 772 7005 FAX: 714 772 7014  
email: info@tokistar.com Website: tokistar.com

## Mounting Fixtures to Wire Rope

### Part#: KSG-MDA

Our wire rope adaptors securely hold each KromaStar socket in place to 1/8" or 3/16" Ø catenary cable. Wire rope and associated mounting hardware are not provided with the system.

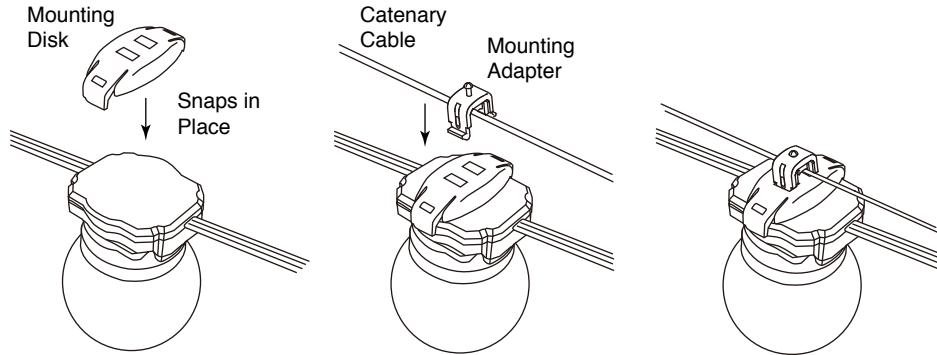

## Surface Mounting with Disks

### Part#: KSG-MD

Mounting disks can be screwed in place to a variety of surfaces. One disk is required for each socket. Make certain the disks are properly aligned to achieve the desired effect.

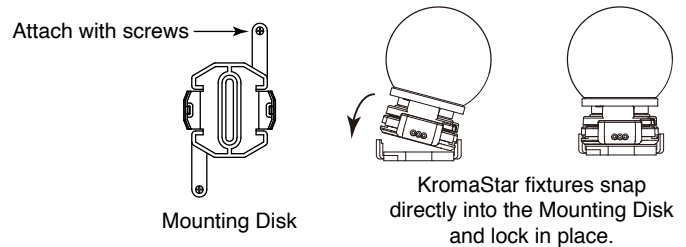

## Surface Mounting with Straps

### Part#: KSG-MS

Mounting straps can also be used to secure fixtures. Two straps are required per socket.

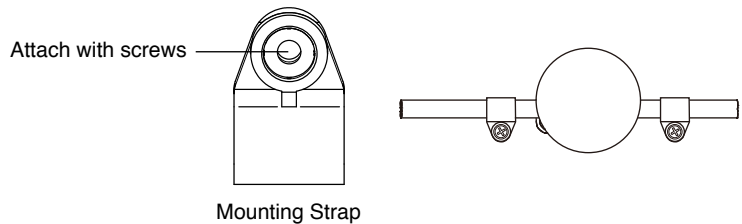

## End Caps - Part#: KSG-ED

KromaStar fixtures are supplied with factory sealed end caps on the end of each run.

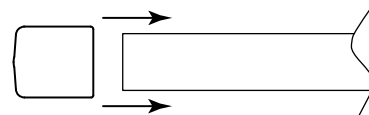

## PRECAUTIONS

Do Not Modify Socket Spacing of KromaStar fixtures.

**Panel/Extrusion Mounting - Part# KSG-PM**

For installations to flat panels or extrusions from 1/25" to 3/16" thick, we offer panel fasteners.

1. Provide a 2 1/8" Ø opening.
2. Press the Panel Fastener Top in place from above.
3. Check the orientation of the socket base and holder, and securely press them together.
4. Insert the fastener and socket base into the opening on the back side of the panel until it firmly clicks in place
5. For panel applications with globes, the globes are shipped separately along with the Flat O-Rings. Place the O-ring around the LED as indicated below before attaching globes.

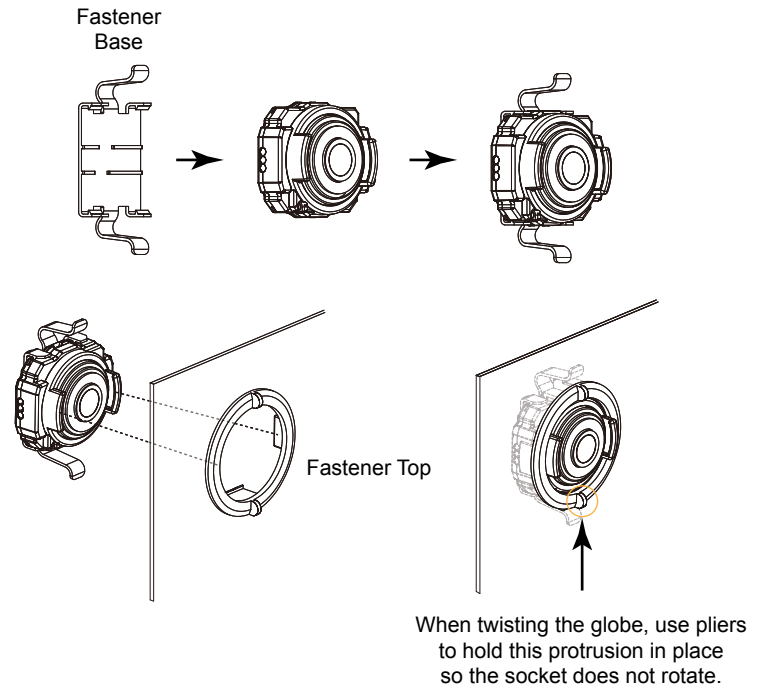
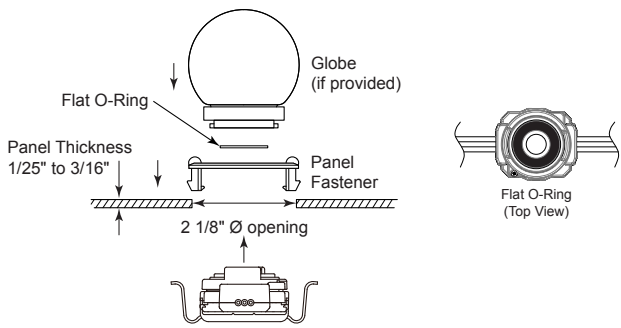

**Mounting Channel - Part# KSG-MC**

For surface mounted installations, our KromaStar mounting channel ensures linear integrity. The channel may be used with either Flex or Globe fixtures.

Channel Length: 94.5" (2.4M)  
 Dimensions: 0.44" x 1.92"  
 Material: Powder-coated aluminum (black)

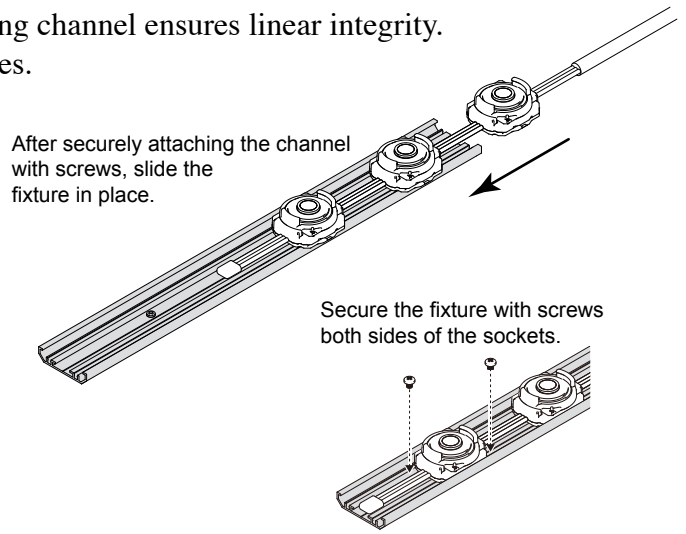
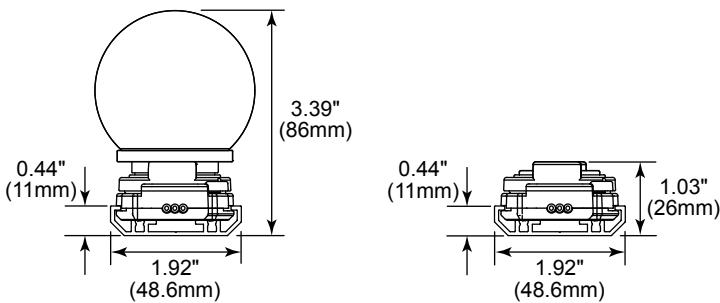

## KSG-EXC Channel Installation Instructions

### KSG-EXC Channel - Part# KSG-EXC

EXC extrusion is available in a 1.5" x 2" aluminum profile for use in all environments. Standard finish is powder coat black aluminum, with custom finishes available upon request. Each fixture is labeled with wattage and operating voltage.

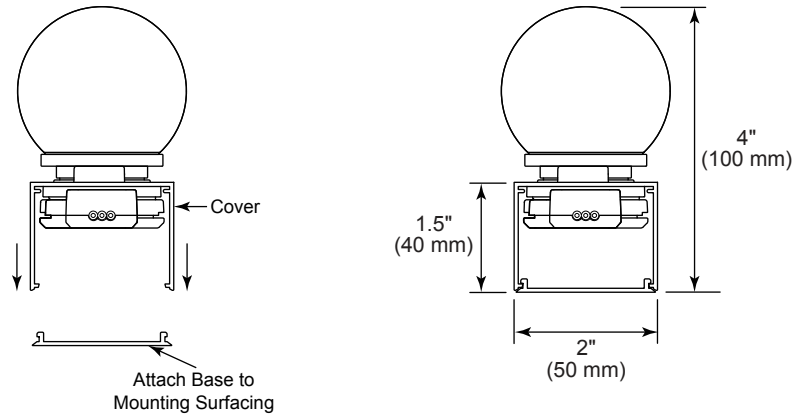

### Mounting Fixtures

**Step 1** - Determine the entry point of wires feeding the fixture (on the side of the Extrusion Cover, End Caps or Base). Drill or punch appropriate size hole to accommodate the conduit fitting used.

**Step 2** - Securely mount the Extrusion Base to the surface with screws and add End Caps to the ends of the fixture runs.

**Step 3** - Check output from LED driver to ensure it is 24 volts.

**Step 4** - Turn circuit to LED driver off, and connect secondary wires from transformer to the fixture cover assembly.

**Step 5** - Snap cover assembly in place.

### Secondary Circuit Wiring

Do not exceed 100 KromaStar LEDs.

#### Secondary Circuit Limitation

Do not exceed 4 Amps  
(96 watts @ 24VDC)

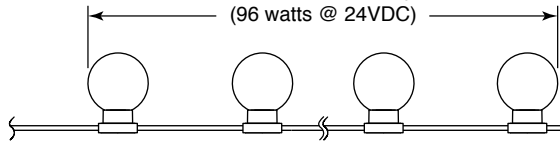

### Recommended Lead Wire Size

The chart on the right indicates recommended wire size based upon the driver being loaded to its full capacity of 4 Amps/96 Watts.

Secondary Lead Wires	
Wire Size	Wire Length
#14 AWG	65' (20 M)

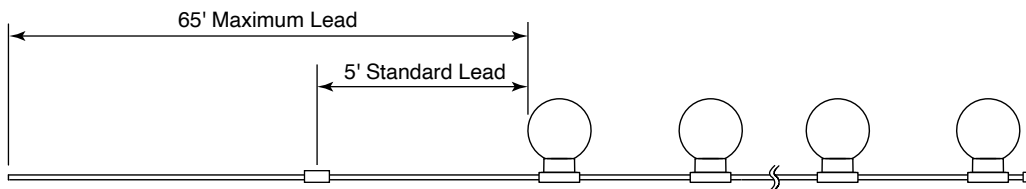

### LED Driver Installation

#### Part#: LDR24-96

This 96 Watt Class 2 LED driver converts an AC input into a 24VDC output. Refer to the manual provided with the LED driver for detailed installation instructions.

Part#	Input Volts	Output Volts	Output Ratings
LDR24-96	100~277	24VDC	1 @ 4 Amps

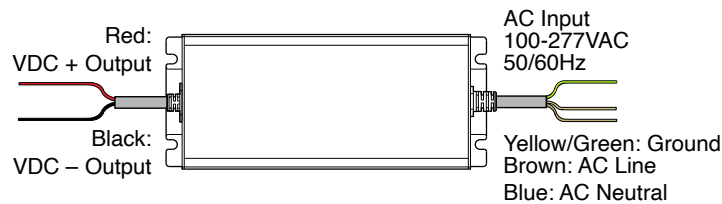

### LED Driver Enclosures

#### Part#: LDR24-ENC-96

#### Part#: LDR24-ENC-192

Tokistar offers a UL Listed enclosure including 1-2 LED drivers and 1-2 Data Converters inside. The enclosure is rated NEMA 3R. Terminal blocks provide reliable and convenient connection points.

The enclosure may be installed at remote locations up to 65 ft. / 20M from the Data Converter with the use of #14 AWG secondary wire.

The enclosure is for dry locations.

Dimensions: 12.13" x 12.13" x 4.25"

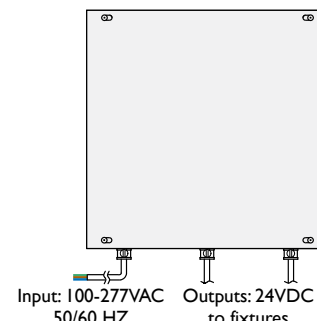

## System Layout

Each KromaStar system requires the following components:

- Lighting Fixtures
- 96 watt/24VDC LED driver
- PWM Data Converter
- Cat5e Cable (provided by others)
- DMX Controller (provided by others)

- One data converter (LC-KSG-MIX) is required for each independent KromaStar fixture. Do Not connect two or more KromaStar fixtures to an LC-KSG-MIX.
- It is possible to connect multiple data converters to an LDR24-96W LED driver if the total capacity does not exceed 96 watts.
- The data converter can be located up to 65' (20M) from a fixture if #14 AWG wire is used.

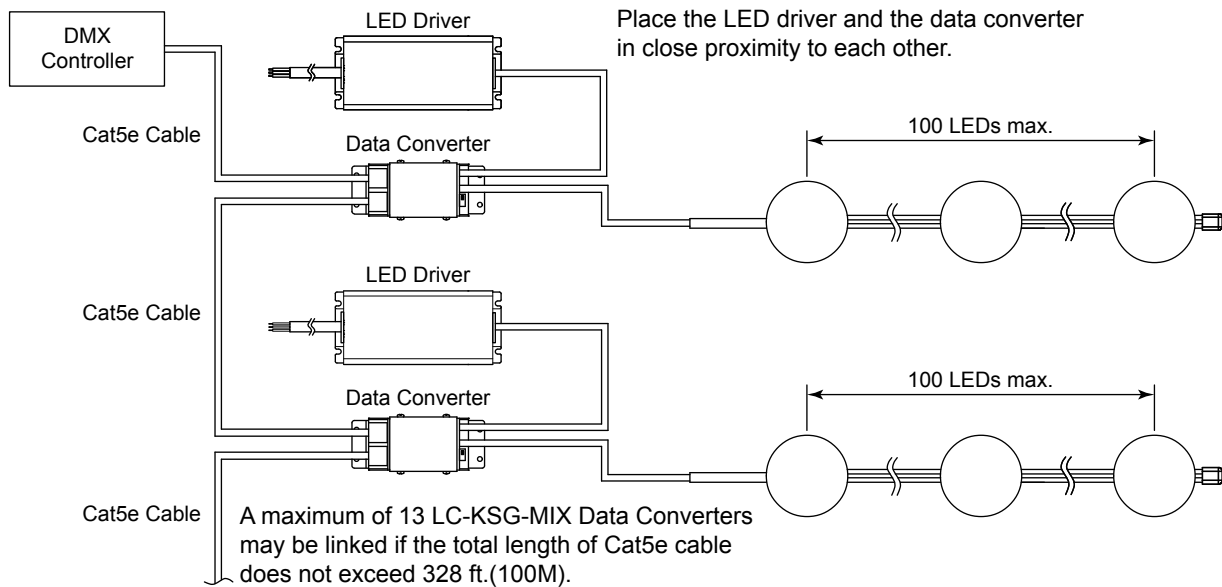

## Data Converter

### Part : LC-KSG-MIX

A 24VDC input from a Tokistar LED driver feeds into the converter and is passed to the lighting fixtures. DMX data is supplied to the converter from a DMX controller and the signal is passed to the fixture. This data should be provided from an isolated line from the controller. It may be necessary to use a DMX splitter to provide the signal.

Do not connect more than one fixture to the converter. This device should be installed in a dry location.

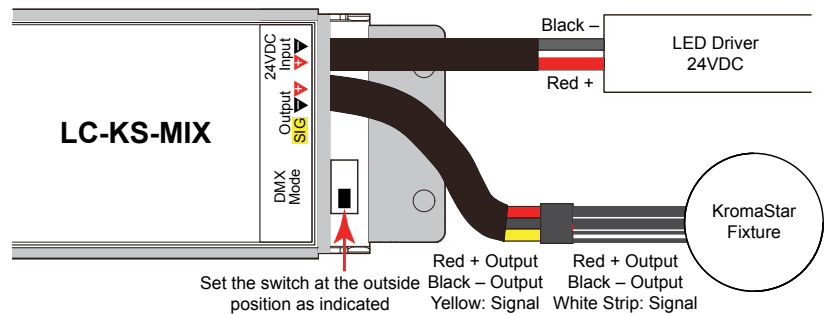

When using multiple LC-KSG-MIX, all switches must be set in the same position.

## PRECAUTION

All dimming components are rated for dry location only. They must be installed within an enclosure suitable for the environment.

# Assigning DMX Addresses

Each LED module contains Red, Green, Blue, and White LED dies. These are given unique DMX addresses at the factory and cannot be changed on site. Unless otherwise specified, we will assign the first globe next to the lead wire to DMX addresses 1-4. Each succeeding module will be assigned the next 4 addresses as shown in the example below with 12 globes.

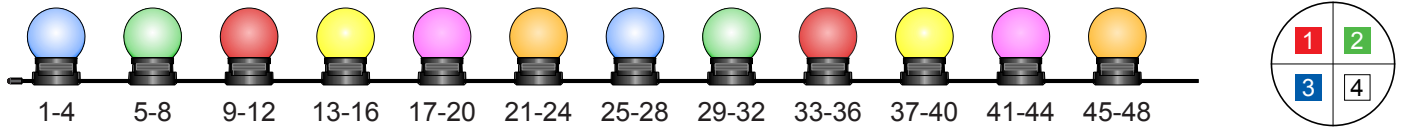

Since each fixture may have up to 100 LED modules, it may take up to 400 DMX addresses. In this case you can program the controller to create colorful animated effects from the beginning of a run to the end as indicated below.

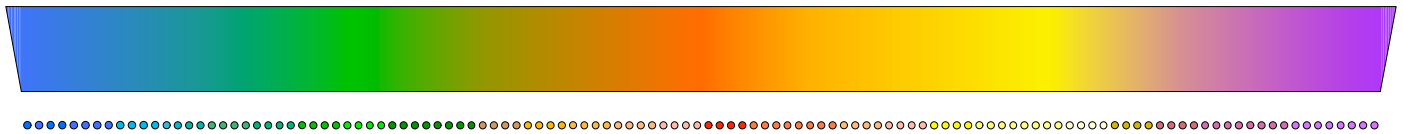

## Replacing LEDs

KromaStar LEDs can be replaced by following the steps below.

### Fixtures with Globes

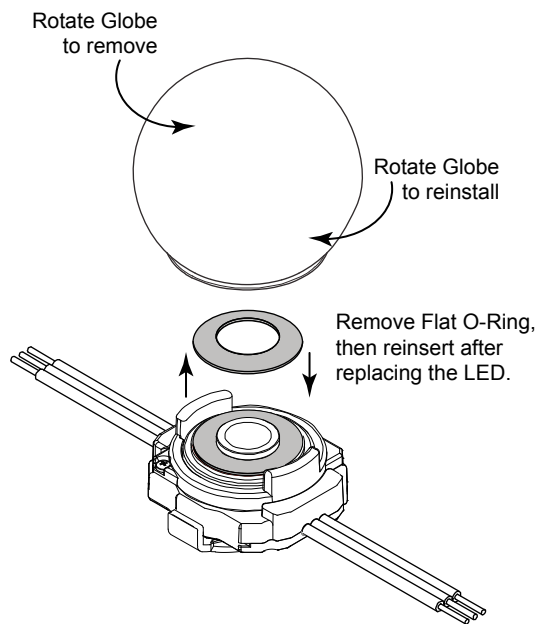

### Replacing LEDs

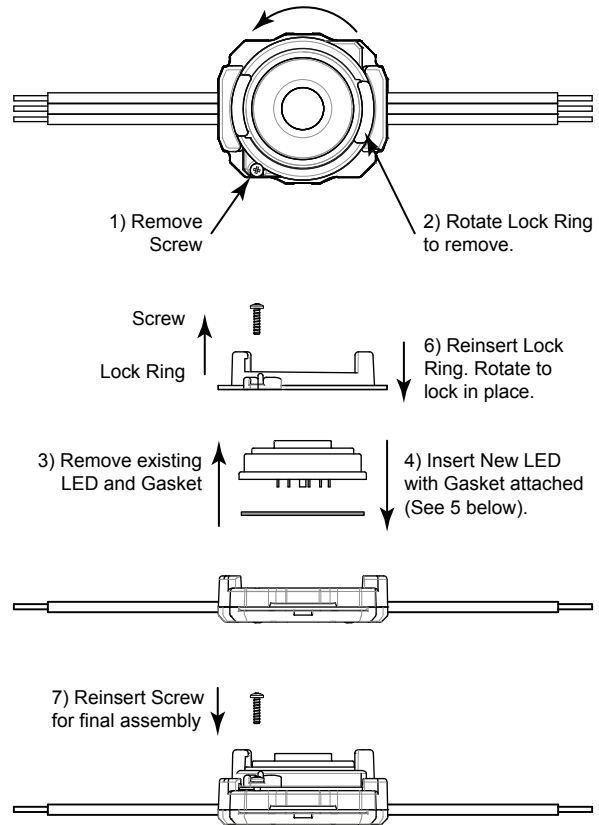

5) When affixing the gasket to back of the new LED, the holes on Gasket must align with LED contacts. Contacts must be completely exposed through Gasket openings.

