

The Tri-Proof Lights are extremely rugged, resistant to heavy impacts (IK10), dust and jets of water (IP66), making them ideal for harsh industrial environments.

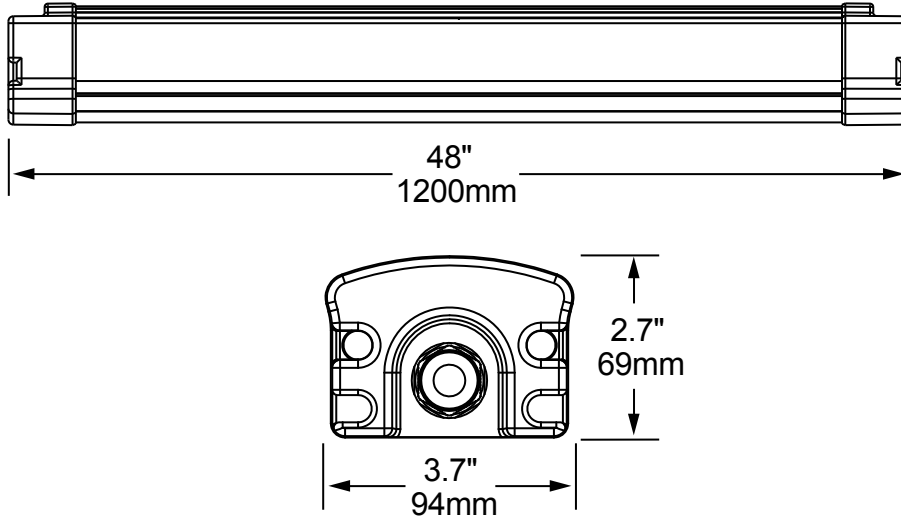

Features

- Water-proof (IP66), Dust-proof, Pressure-proof (IK10)
- Luminous Efficacy (LPW): 110-120 lm/W
- Available in 4 ft. length / 40W version
- Excellent heat dissipation
- Impact resistant (IK10)
- 50,000 hours life
- Energy efficient – up to 80% energy savings
- cETLus and DLC listed

Applications

- Hallways
- Lobbies
- Banquet Hall
- Retail
- Restaurants

Ordering Code:

SL66 - 4FT - 40W -



COLOUR TEMPERATURE

30 - 3000K

40 - 4000K

50 - 5000K

65 - 6500K

Specifications

Watt	40
Input Voltage	100-240V/277V
LEDs	240
Working	DC34-40V
Luminous Efficacy	110-120lm/W
CRI	>80
Beam Angle	120°
THD	<15%
Warranty	5 Years
Power Efficiency	Yes

*NOTE: 4000K IS STOCK, ALL TOHER COLOUR TEMPERATURES ARE SPECIAL ORDER

Project		Type	
Date		Contact	
Notes			