

## MOUNTING INSTRUCTIONS

1. First remove fixture cover by unscrewing two bolts holding cover to can.
2. Remove LED Brick Star reflector by unscrewing the screws, holding reflector in place. See schematic on adjacent page.
3. Using a knife, or very thin flat blade screwdriver, remove reflector and set beside fixture.
4. Select a mounting location for the LED Brick Star. Fixture should be within reach of 120VAC power, located 9 inches above the surface to be lit, and situated at the best location along the mounting surface for the illumination task.
5. LED Brick Star may be used in any standard brick wall in lieu of a brick. Make sure LED Brick Star is completely wired and inspected before wall is completed. NOTE: Masonry wall installation warning adjacent schematic, and corrosion warning on reverse side.
6. LED Brick Star has flanges that will allow the can to be securely affixed to almost any surface with the four mounting screws provided. Installations in drywall will require a wood backing behind drywall. Place can in hole (7-3/4" x 3-1/4" x 2-1/2") and mark the position of the four mounting screws. Reposition can in hole, and securely fasten the can to the mounting surface by firmly tightening four mounting screws.

## WIRING INSTRUCTIONS

**CAUTION!** Only qualified electricians, or people familiar with household electrical circuits, should bring 120VAC power to the fixture. Wiring may require an inspection by the local building department. Check with your local building department before installation.

**CAUTION!** Before bringing 120VAC power to the fixture, make sure incoming wire is not "hot" and all power coming to the wire is off.

**CAUTION!** All connections must be made in accordance with this instructional manual, current CEC, and all local building codes. Minimum 90 C supply conductors.

**CAUTION!** Use RTV silicone and water-tight fittings on all wet locations connections to fixture.

1. Through one of the three NPT fittings provided, bring in 120VAC power wiring. If 120VAC wire will not conveniently enter one of the three NPT fittings provided, simply unscrew the can, rotate can 180 degrees, and reinstall. Can is entirely symmetrical, and 180 degree rotation will not affect mounting holes.
2. Secure wire to fixture with the appropriate strain relief (not provided).
3. Strip 1/3" (8mm) of the insulation off each incoming 120VAC power wire. Connect white incoming 120VAC wire (neutral wire) to push-in connector on white wire from LED module. Connect black wire from LED module. Connect ground wire to push-in connector on green wire screwed into can. Push all wires firmly down into connectors, so that uninsulated wire is not exposed.
4. Reinstall assembly, reflector, and cover.

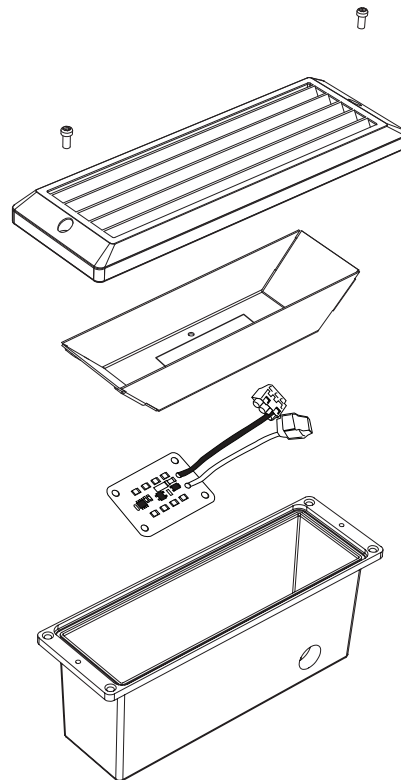

## REPLACEMENT OF LED ASSEMBLY

In the highly unlikely event of an LED module failure, please follow the instructions listed below:

**CAUTION!** If unit has recently been operating, glass lens and LED module are hot! Turn off fixture and allow it to cool for 15 minutes before relamping.

**CAUTION!** Always turn off the main power, before replacing the LED module.

**NOTE:** Using a thin pair of gloves during this procedure will eliminate fingerprints on glass lens and LED module.

1. First remove fixture cover by unscrewing two bolts holding cover to can.
2. Remove the reflector by unscrewing the screws holding it in place.
3. Disconnect the LED module from 120V wires. Please make sure that the 120V wires are not "hot".
4. Remove the LED module by unscrewing the screws holding it in place. Replace it with a new one. Tighten screws just snug.
5. Re-connect the power wires to the LED module.
6. Replace the reflector by tightening the screws.
7. Replace fixture cover by fitting cover to can so gasket seals and screwing in both cover bolts firmly.

**WARNING!** If this fixture is to be placed in a masonry or brick wall, you must use a Concrete Cap during can installation to provide the proper void for the fixture cover. Failure to use the Concrete Cap will almost guarantee concrete or grout forming against fixture can flange, and poor cover-to-can seal (see below). Poor cover seal will allow water/moisture into fixture resulting in LED failure.

### Without Concrete Cap

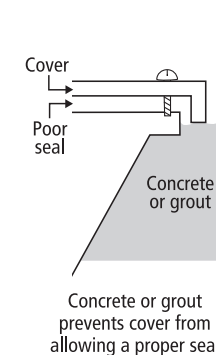

### With Concrete Cap

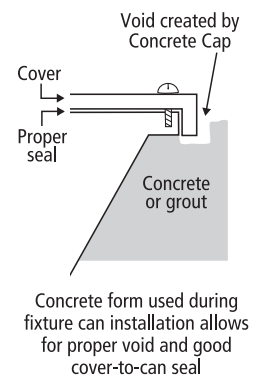

## DIMMING

The LED Brick Star could be dimmed using dimmers with forward phase TRIAC design.

Recommended manufacturer and model numbers are listed below:

LUTRON SCL-153PH  
LUTRON CTCL-153P  
LEVITON 6674  
LEVITON IPL06

## ANOTHER LED PRODUCT BY NSL

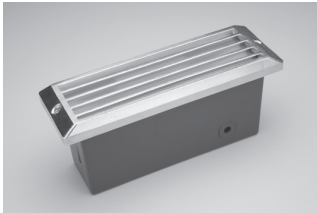

Stainless Steel Louver Cover with fluorocarbon lacquer coated aluminum can. Recommended for use in corrosive environments as salt air, adjacent bodies of water, or installed in caustic materials such as limestone.

## THROUGH-WIRE, 120VAC POWER

- Disconnect from all 120VAC power prior to installation.
- Connections must be made in accordance with all local electric codes and/or CEC.
- Minimum 90°C supply conductors.
- For maximum load with dimmer, consult dimmer instructions.
- 14 gauge (Romex Type) or better wire is required.
- Requires strain reliefs.
- Installations in wet locations should use RTV silicone or water-tight fittings on all connections to fixtures.

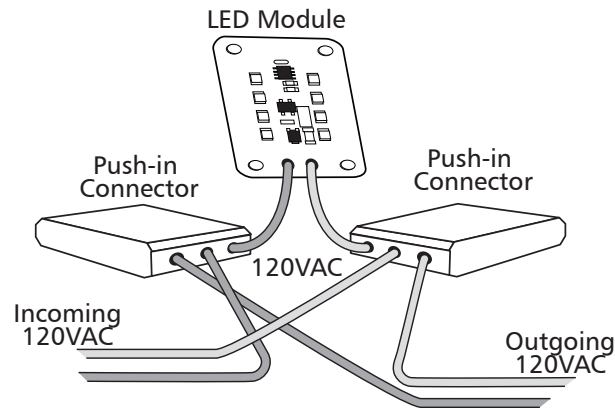

## INSTALLATION INSTRUCTIONS

# LED BRICK STAR GEN II

**120 VDC LED technology  
in a brick-size die cast  
aluminum fixture**

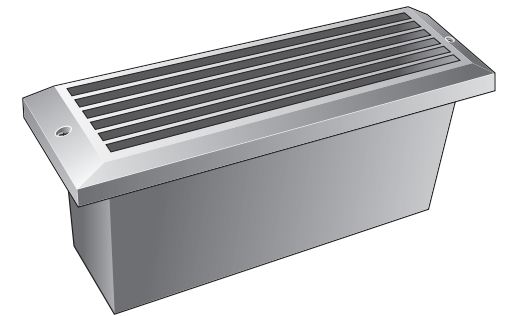

Ultra low 5.2 watts per fixture

Dimmable

Louver, Scoop & Prism cover designs

White, Bronze, Black and Aluminum colours  
Stainless Steel Louver Option

Suitable for:

Wet Locations, Insulation Contact  
Wall and Ceiling Mount, Showers  
Use in Poured Concrete



**M** | **MAGIC LITE**  
YOUR TRUSTED LIGHTING PARTNER

**M** | **MAGIC LITE**  
YOUR TRUSTED LIGHTING PARTNER