

# Exhibitor Custom Shades

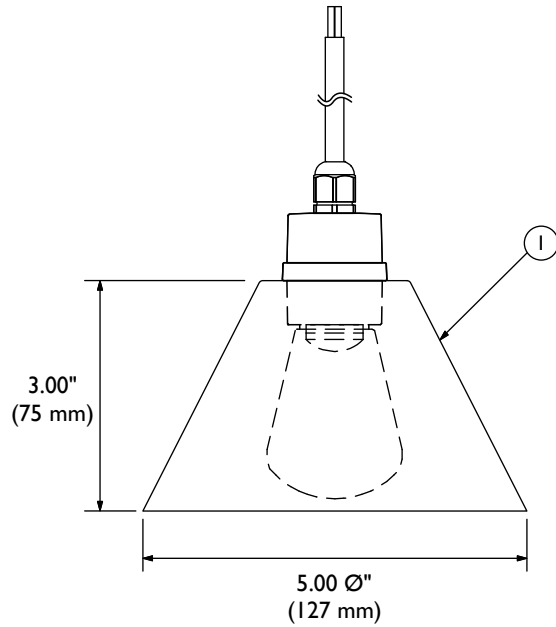

**Part#: EX-CS1-B**  
shown w/S-14 Globe

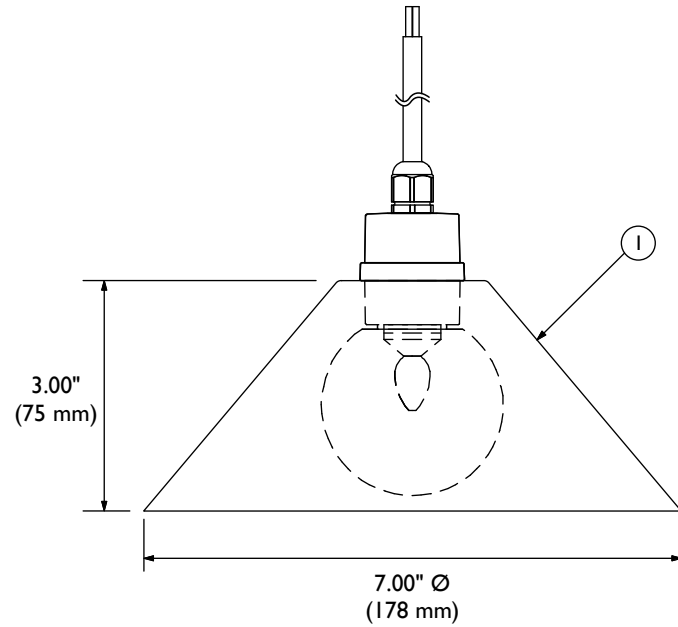

**Part#: EX-CS2-B**  
shown w/G-19 Globe

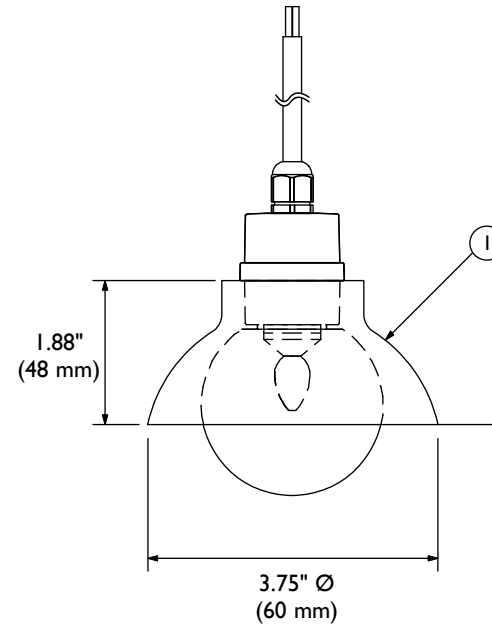

**Part#: EX-CS3-B**  
shown w/G-19 Globe

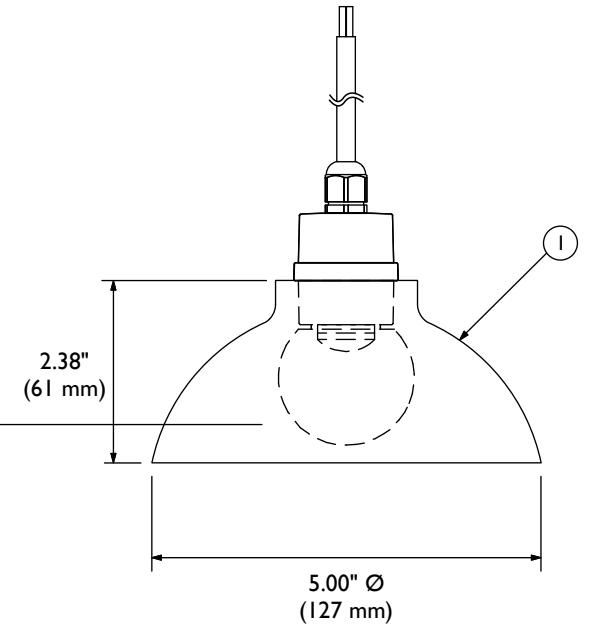

**Part#: EX-CS3-B**  
shown w/G-14Globe

Standard finish is black.  
Custom finishes available upon request.

Shades are shown with Exhibitor Pendants,  
they can also be used with Exhibitor Festoon applications.



**TOKISTAR LIGHTING INC.**

1015 E. DISCOVERY LANE  
ANAHEIM, CA 92801  
TEL: 714 772 7005 FAX: 714 772 7014  
email: info@tokistar.com Website: tokistar.com

Exhibitor Shades	No.	Part	Material
Catalog#: EX-CS-(1,2,3,4)-B	1	Custom Shade	Spun Aluminum
Date: February 1, 2020	2		
Drawn By: R. Cordova	3		
Scale: 1:2.5	4		
Weight: EX-CS1-B = 95g/0.21 lb	5		
EX-CS2-B = 154g/0.34 lb	6		
EX-CS3-B = 38g/.084 lb			
EX-CS4-B = 59g/0.13 lb			