

LED Brick Star provides a safe, attractive and affordable way to light stairs, aisles, paths and entrance ways.

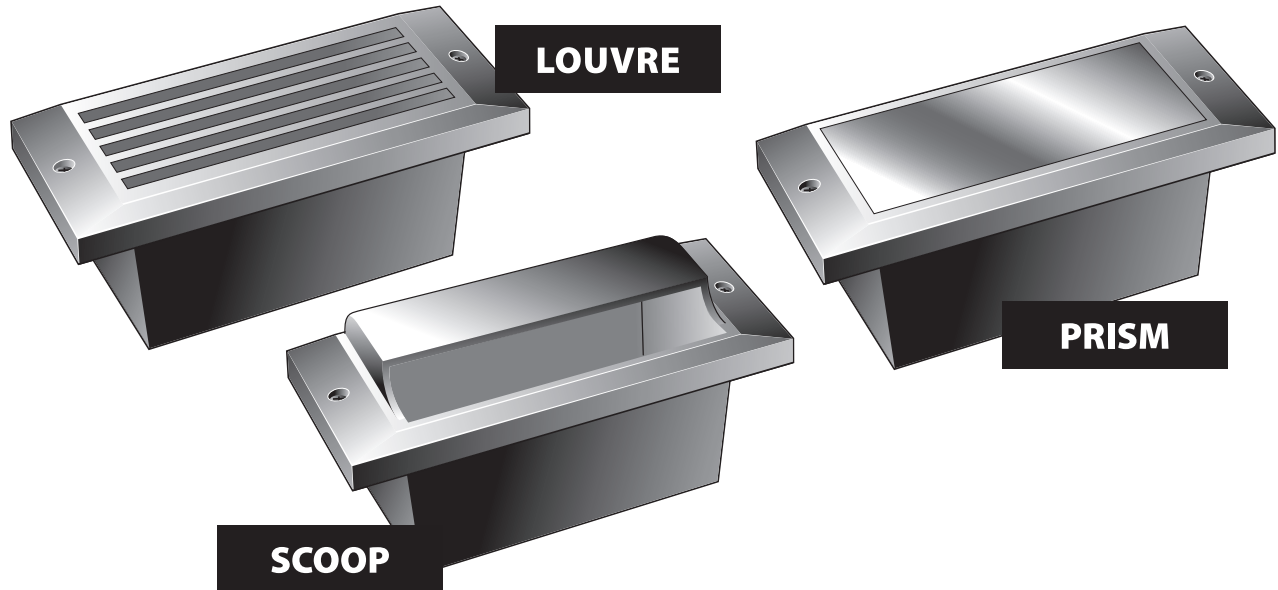

Features

- 40,000-hour LED life
- Ultra low 5.2 watt energy usage per fixture
- CRI 80+
- Lumen output: 468LM
- 120VAC power input
- Up to 150 LED Brick Star lights per 120VAC tap
- Die cast aluminum can and cover
- Available in fluorocarbon can with stainless steel louvre cover
- Fits into any standard brick, or in any void sized 73/4" x 21/2" x 31/4" (196.6mm x 63.5mm x 82.6mm)
- cETLus listed for indoor and outdoor applications including wet, IC, concrete pour, ceiling and shower locations
- Dimmable with most forward phase TRIAC dimming systems
- 3 year limited warranty

Specifications

LED Colour	White (3000K +/-200)
Input Voltage	120V AC
Power Consumption (W)	5.2 Watts
Lumen Output	468LM
Can Finish	Powder Coated White, Fluorocarbon Lacquer (Stainless Steel)
CRI	80+
Life Span (hours)	40,000
Lens	Frosted tempered glass
Wiring Options	Up to 150 LED Brick Star lights per 120VAC tap
Approvals	cETLus listed for wet and IC locations

Ordering Code:

LEDBS-II-WH- -

Cover Option Finish Colour

L = Louvre WH = White
P = Prism BK = Black
S = Scoop BZ = Bronze
 SS = Stainless Steel*

**Available for Louvre option only*

Project		Type	
Date		Contact	
Notes			

LED Brick Star provides a safe, attractive and affordable way to light stairs, aisles, paths and entrance ways.

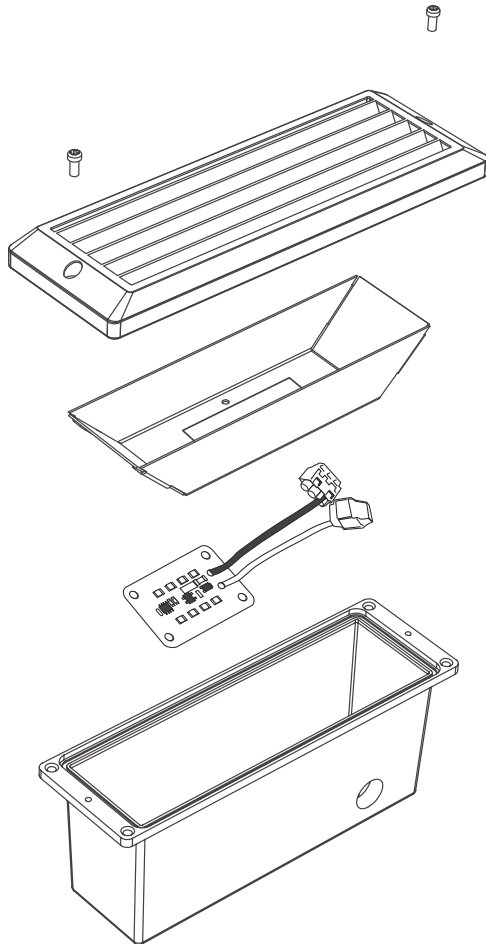

NOTE: for concrete installations,
please use the concrete cap BL-CC

