

MOUNTING AND WIRING INSTRUCTIONS

1. First release glass diffuser lens by unscrewing bolts on either side of lens just enough to release diffuser lens. The glass diffuser lens will swing down. Lens cover will hold bolts in place.

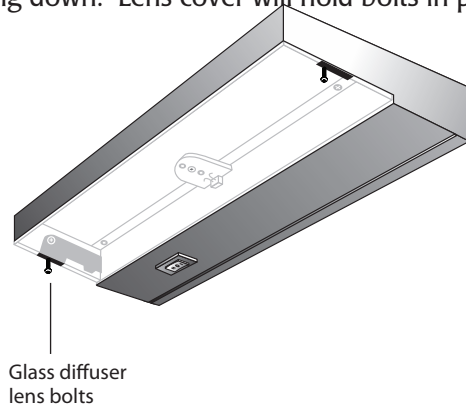

NOTE: Four and five module units have magnet(s) on center of lens which will require a gentle pry downward with a small screwdriver on the lens to release.

2. Easy mounting is assured by simply positioning fixture on mounting surface and driving the two pre-positioned screws into underside of cabinet with a power screwdriver. See below.

NOTE: For wall or under cabinet mount only.

CAUTION! Only qualified electricians, or people familiar with household electrical circuits, should bring 120V power to the fixture. Before bringing 120V wire to fixture, make sure incoming wire is

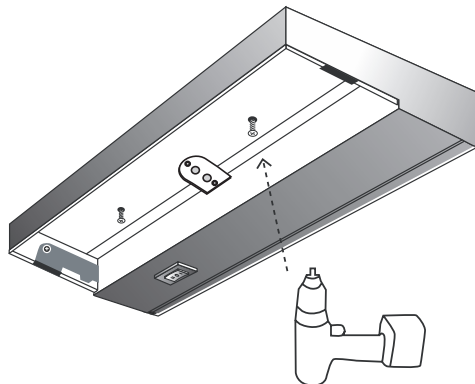

not "hot" and all power to wire is off. Not for use with rigid conduit systems. Use flexible conduit to attach to fixture.

3. Open wiring compartment cover by unscrewing wiring compartment bolts. Metal leashes will hold bolts. Press metal tabs on each end of fixture. Wiring compartment cover will swing down.
4. Through one of the many knockouts provided, bring in 120V power wiring. Secure to fixture with appropriate strain relief.
5. Strip 1/3" (8mm) of the insulation off each incoming 120V power wire. Connect white wire (neutral wire) to push-in connector on white wire from LED driver. Connect black incoming 120V power wire (hot wire) to push-in connector on black wire from switch. Connect ground wire to push-in connector from ground wire attached to fixture. Push all wires firmly down into connectors, so that uninsulated wire is not exposed.

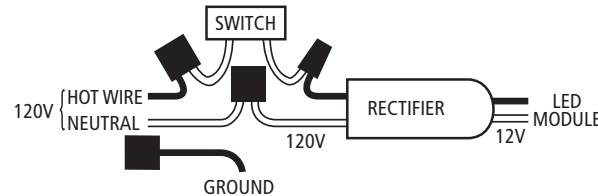

6. Check all connections. Close wiring cover by pushing firmly into fixture until thumb release "clicks" into place. Tighten wiring compartment bolts.
7. Replace glass diffuser by swinging glass lens into position and tightening lens cover bolts snug
8. Apply 120V power to incoming wiring.
9. Dimming.

There are two ways at present to dim the LED Task Star:

1. The first option consists of dimmers with forward phase TRIAC design and HED technology. These dimmers tend to be less

expensive and have shown very good results. These dimmers also have an advantage of requiring only two wires within the switch box in a single pole configurations (HOT and GROUND). For optimum results these dimmers also have a dimming range adjustment. Maximum load for these dimmers is 150W. Recommended manufacture and model numbers are below:

LUTRON "Skylark" SCL-153P
LUTRON "Skylark Contour" CTCL-153P
LUTRON "Diva" DVCL-153P

2. The second option consists of dimmers with 'trailing edge' electronic design. These dimmers have shown slightly more even dimming results and are generally considerably more expensive. Trailing edge dimmers will require the switch box to contain all three wires (HOT, NEUTRAL, and GROUND). Maximum load for these dimmers is 300W. Recommended manufactures and model numbers are:

LUTRON "Skylark" SELV-300P
LUTRON "Skylark Contour" CTELV-303P
LUTRON "Diva" DVELV-300P

Note: All the specified dimmers will dim down to 5-10%. All specified dimmers also have an integral on/off switch to eliminate any light from the fixtures. Please read and follow dimmer manufacture instructions.

RELAMPING INSTRUCTIONS

In the highly unlikely event of an LED module failure, please follow the instructions listed below:

CAUTION! If unit has recently been operating, glass, LED modules, and fixture are hot! Turn off fixture and allow it to cool for 15 minutes before relamping.

CAUTION! Always replace LED modules with fixture switch in the OFF position.

NOTE: Using a thin pair of gloves during this procedure will eliminate fingerprints on glass lens and LED modules.

1. First remove glass diffuser lens by unscrewing two bolts holding glass diffuser lens to fixture
2. Push down on LED module male connector clip. This will disengage connector clip from female connector side in fixture. With connector clip free, gently pull connector apart.
3. Unscrew old LED module. Replace with new LED module (Magic Lite part No. LEDMOD-HVDC). Tighten screws just until snug.
4. Push male connector from LED module into female connector in fixture. Make sure male connector clip engages to female connector.
5. Replace glass diffuser by swinging glass lens up into position and tighten bolts snug.

| Product Code | Energy Usage |
|--------------|--------------|
| LTS-1-HW/XX | 5.2 W |
| LTS-2-HW/XX | 10.4 W |
| LTS-3-HW/XX | 16.6 W |
| LTS-4-HW/XX | 20.8 W |
| LTS-5-HW/XX | 16.0 W |

XX = finish colour
 AL - aluminum
 BK - black
 BZ - bronze
 WH - white

THROUGH-WIRE, 120V POWER

- Disconnect from all 120V power prior to installation.
- Connections must be made in accordance with current Canadian Electrical Code and all local building codes.
- Interconnect up to 150 LED modules maximum.
- 14 gauge (Romex Type) or better wire is required.
- Requires strain reliefs.
- Dimmable.

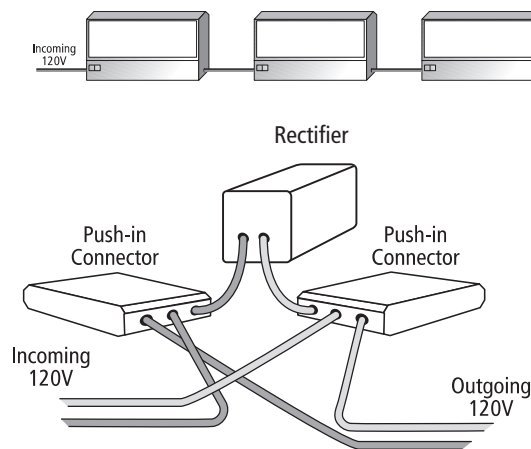

MAGIC LITE LTD.

2526 Speers Road, Unit 4-9
 Oakville, Ontario, Canada L6L 5M2

Tel: 905-825-9592 • Out of Area: 1-888-945-5483 • Fax: 905-825-8334
www.magiclite.com

INSTALLATION INSTRUCTIONS

LED TASK STAR

Self-Contained LED Task Light Fixture

Hard Wire Version

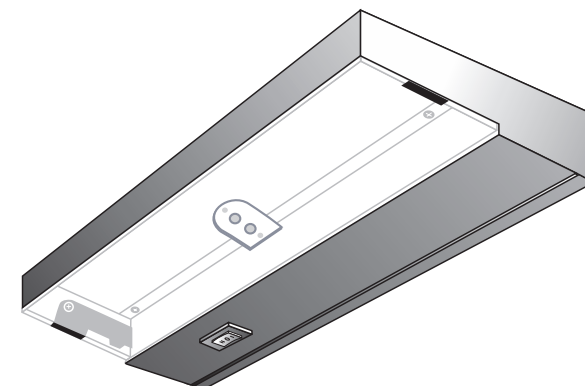

Under cabinet task light

- * Bright enough for writing and detail work
- * Integral on/off switch
- * Cooler and safer than halogen lights
- * 40,000 hour LED life
- * Suitable for Damp Locations



MAGIC LITE LTD.



Damp Location