

100W LED Work Light

The LED Work Light is an energy savings, impact resistant long life temporary lighting solution for illuminating workplaces, shops, garages, and warehouses.



FEATURES

- Spring loaded hook
- 10ft power cord with plug
- 6KV/10KV surge protection
- Hidden, built-in hidden socket
- Eye-catching housing
- Stainless steel guard
- Epistar LEDs
- Hollow heat sink
- Silicone gaskets for damp location use
- 5 years limited warranty

APPLICATIONS

- Construction sites
- Machinery illumination
- Automotive garages
- Industrial warehouses
- Repair shops
- Outdoor night projects

SPECIFICATIONS

Product Code	LWL-100W-50	
Electrical	Input Voltage	120V AC, 50-60Hz
	Power Consumption	60W
Specs	Colour Temperature	5000K
	CRI	80+
	Lumen Output	13,500 Lm
	Efficacy	135 LM/W
	Beam Angle	360°
LED	Type	Epistar 2835
	Life Span	50,000 Hours
	# per foot / unit	408
Design	Dimensions (Inches)	6.5 x 11.5"
	Dimensions (Millimeters)	165 x 292mm
	Finish Colour / Trims	Black, yellow
	Product Material	Stainless steel guard
	Max Single Run Length	10 LED work lights
	Operating Temperature	-20°C to 40°C
	Approved Location	Damp
	Mounting	Optional tripod, floor mount, magnet mount accessories
Warranty	5 years	
Approvals	cULus, listed for damp location	

PRODUCT CODES

LWL - 100W - 50

DIAGRAM

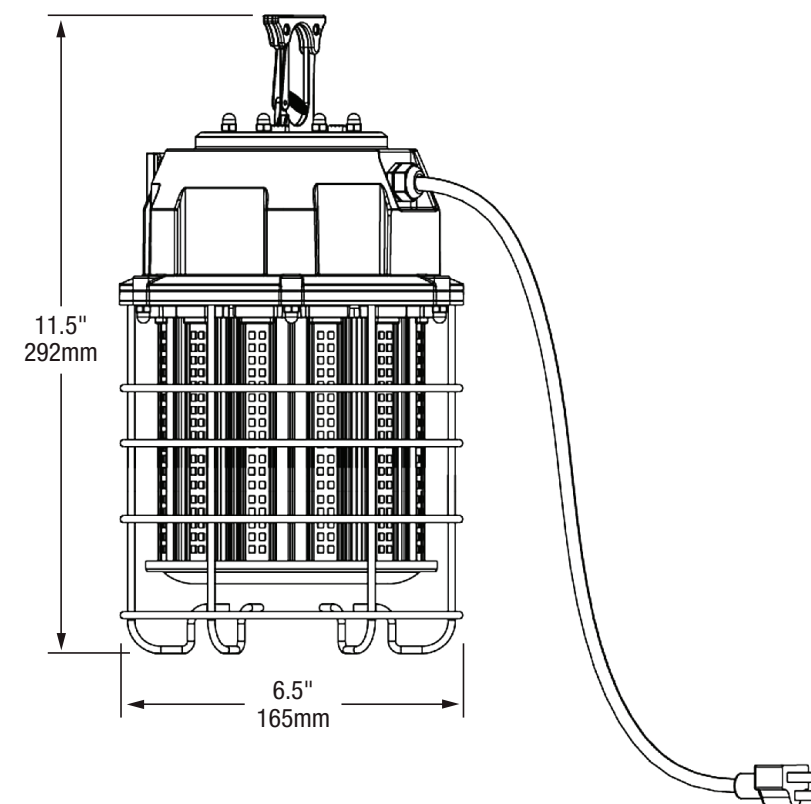

ACCESSORIES

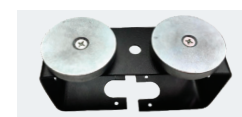

LWL-MM
Magnet mount kit



LWL-FM
Floor mount kit

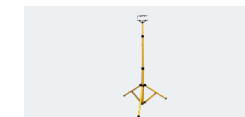

LWL-TM
Tripod mount kit